

PX136

LED Driver
3 x 350 mA

INSTRUCTION
MANUAL



CONTENTS

1. General description.....	1
2. Safety conditions.....	1
3. Connections and control elements description.....	2
4. Displayed messages meaning.....	2
5. DMX address setting.....	3
6. FLP feature.....	3
7. MASTER / SLAVE feature.....	4
8. White balance.....	5
9. Colours' mode.....	5
10. Individual settings.....	5
11. Reaction to DMX signal interruption.....	6
12. Programs' description.....	7
13. Brightness control frequency.....	8
14. Control frequency fine tuning.....	8
15. Connections scheme.....	8
15.1 6-wire connection.....	9
15.2 4-wire connection.....	9
16. Programming.....	10
17. PxLink protocol.....	11
18. Dimensions.....	11
19. Technical specification.....	11
20. Declaration of conformity.....	12

Manufacturer reserves the right to make modifications in order to improve device operation.

<i>PXM s.c.</i>	<i>tel.: (+48 12) 626 46 92</i>
<i>ul. Przemysłowa 12</i>	<i>fax: (+48 12) 626 46 94</i>
<i>30-701 Kraków</i>	<i>E-mail: info@pxm.pl</i>
<i>POLAND</i>	<i>Internet: www.pxm.pl</i>

1. GENERAL DESCRIPTION

The PX136 driver is intended for LEDs control. The built-in DMX signal receiver allows to control 3 channels (R, G, B) directly through DMX protocol. The wide range of feeding voltage and high load capacity allow to control great number of LEDs.

PX136 can be controlled with DMX signal or operate independently. In this case the user has at disposal a fully programmable scene and 19 factory-defined sequences, for these the user can adjust the playing speed and step-to-step fading smoothness.

Driver has a built-in control signal frequency adjustment system ("flicker free" technology), what makes it particularly helpful in the TV industry applications.

Seeing that the RGB LEDs parameters differ notably quite often, it may cause troubles with achieving the white colour (when all the output channels are controlled at 100%). That is why the PX136 driver has the "white balance" feature. By dint of this feature the user may fit the corrected module control of every colour to each set of LEDs, as to achieve white colour at full operation. What is more, this feature allows to correct in a narrow range the white hue temperature.

The module accepts PxLink protocol, that allows to remotely set the DMX address to each lamp, without physical interference in the lamps' settings. This protocol has been entirely created by PROXIMAS.c.

2. SAFETY CONDITIONS

PX136 LED Driver 3 x 350 mA is a device powered with safe voltage 24 V; however, during its installation and use the following rules must be strictly observed:

1. The device may only be connected to 12 - 24 V DC (stabilized voltage) with current-carrying capacity compatible with technical data.
2. All the conductors should be protected against mechanical and thermal damage.
3. In the event of damaging any conductor, it should be replaced with a conductor of the same technical data and attestations.
4. Connection of DMX signal can only be made with shielded conductor.
5. All repairs and connections of outputs or DMX signal can only be made with cut off power supply.
6. PX136 should be strictly protected against contact with water and other liquids.
7. All sudden shocks, particularly dropping, should be avoided.
8. The device cannot be turned on in places with humidity exceeding 90%.
9. The device cannot be used in places with temperature lower than 2°C or higher than 40°C.
10. Clean with damp duster only.

3. CONNECTIONS AND CONTROL ELEMENTS DESCRIPTION

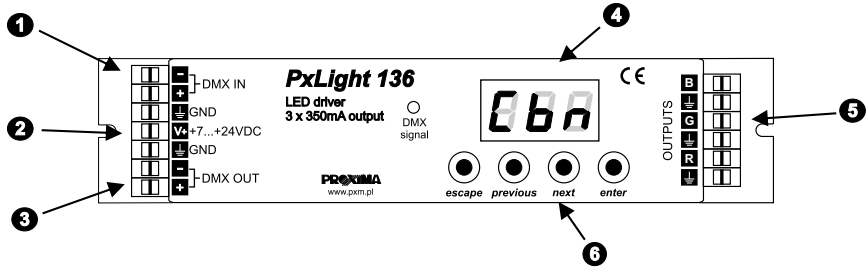

- ❶ DMX-512 input
- ❷ Power supply
- ❸ DMX-512 output
- ❹ Display
- ❺ Control outputs
- ❻ Programming keys

4. DISPLAYED MESSAGES MEANING

- 001** driver's DMX address - the basic *menu* state
- ALL** setting the parameters for all channels concurrently
- Ind** setting the parameters individually for each channel
- FLP** turning the display readings upside-down
- AdP** DMX address setting
- Ebn** control mode settings (RGB or BRIGHTNESS / COLOUR)
- noS** reaction on DMX signal interruption
- E-d** MASTER / SLAVE mode settings
- 2bB** operation in BRIGHTNESS / COLOUR mode
- 3bB** operation in RGB mode
- onB** turning all the outputs on at 100%
- off** turning all the outputs off
- 5cB** scene
- P17** program no. 17
- Ad1** DMX address setting for the first channel
- EoB** turning the MASTER mode on / off

CHn emitted channels number in the MASTER mode

BAW white balance setting

BLR red colour balance

BGG green colour balance

BLB blue colour balance

BCn turning the white balance on / off

SPd program playing speed

FRd program step-to-step fading smoothness

REd red colour setting during scene programming

GRn green colour setting during scene programming

BLL blue colour setting during scene programming

5. DMX ADDRESS SETTING

PX136 module menu allows to set the device's DMX address in a range from 1 to 510. The module takes up 3 subsequent DMX addresses, when set to 510, last channel has 512 address.

To set the DMX address:

1. Select *Adr* menu.
2. With "next" or "previous" buttons set the required DMX address.

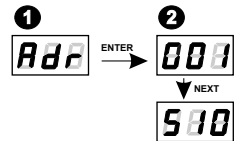

6. FLP FEATURE

As the module should be installed in a small distance from the controlled LEDs, the lack of space may force the necessity of mounting the device upside-down.

In such case the displayed messages become illegible, that does not have the influence on device operation, but makes the programming much more difficult.

That is why the PX136 driver has a FLP feature available from the main menu.

After confirming the settings the displayed messages are turned of 180 grades. The keys order is reversed as well.

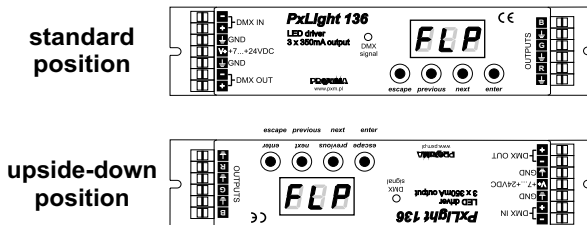

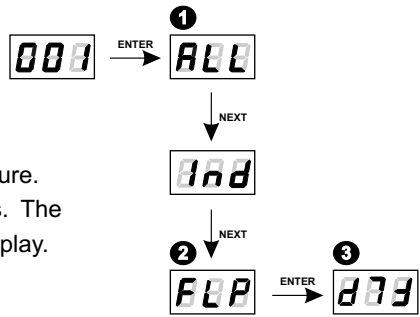

To turn the display upside-down:

1. Enter the *ALL* settings.
2. With “next” or “previous” keys find the *FLP* feature.
3. Press “enter” key to confirm your settings. The upside-down *FLP* inscription will show on a display.

7. MASTER / SLAVE FEATURE

The PX136 module is equipped with DMX-512 signal receiver and can be controlled with any DMX desktop. In addition, the driver has a built-in programmable reaction on DMX signal interruption (*noS*). By dint of 19 factory-defined programs you can obtain interesting effects without the external controller. But in the complex installations a few PX136 modules realizing the same sequence cannot guarantee the full playing synchronization. That is why the PX136 driver is provided with the MASTER feature. When this feature is active, the module becomes the DMX signal transmitter and sends to all the other modules (set as SLAVES, DMX signal receivers) the realized program. By dint of such a solution the precise synchronization, even in very complex installations, is possible.

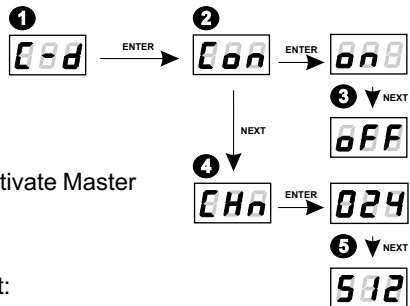

To turn the MASTER feature on:

1. Enter the *C-d* menu.
- 2, 3. In the *Con* settings you can activate or deactivate Master feature, by setting it *on* or *off*.

To choose the number of DMX channels to be sent:

4. Enter the *Chn* menu.
5. With “next” or “previous” keys set the required value. You can choose from range from 24 to 512.

ATTENTION:

PX136 basically sends three channels (R, G, B), but because the DMX standard defines the minimal emitted channels number as 24, these three channels are duplicated eight times. If there is such a necessity, you can multiply them up to 512 channels (this setting is not recommended because of the decrease of a transmission speed).

8. WHITE BALANCE

Sometimes troubles with achieving the white colour on RGB LEDs may occur. It can be caused by applying diodes of different technical specification. For that reason the PX136 module is provided with the white balance feature. With this feature you can set the right colour temperature for full control of all three outputs (white colour). The maximal value (100) is set by default, the temperature can be adjusted by reducing it to a required level (to 50 maximum).

To adjust the white balance:

1. Enter the *bAL* feature.
2. For each channel set the required value:
bLr - for the red channel,
bLG - for the green channel,
bLb - for the blue channel.
3. Enter the *bCn* menu, to confirm your settings or discard the adjusted values.
4. The on setting turns the white balance on, oFF turns the white balance off.

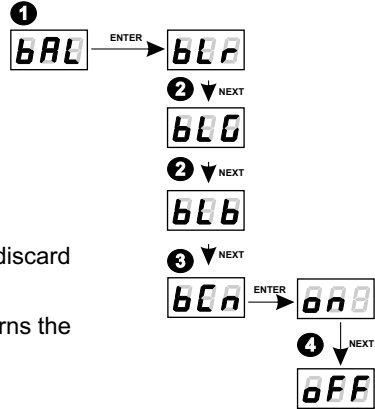

9. COLOURS' MODE

PX136 can operate in HSL, 4-channel, 3-channel and 2-channel mode. The HSL mode operates on 3 channels, each channel regulates in turn: hue, saturation and lightness. 4-channel (4-bytes) mode adjusts the colours separately (red, green and blue) and on the 4th channel the Dimmer (all outputs' dimming) feature is implemented. In the 3-channel (3-byte) mode each of RGB colours is adjusted separately and in the 2-channel (2-byte) mode one channel sets the brightness and the second selects one of the 256 factory-defined colours.

To set the colours mode, enter the *Cbn* feature in the *ALL* menu and select the required colours mode: *2b* for 2-byte mode, *3b* for 3-byte mode, *4b* for RGBDimmer mode or *HSL* for Hue/Saturation/Lightness.

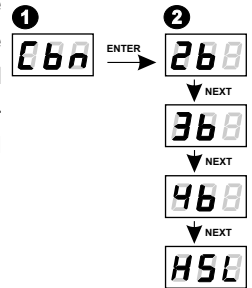

10. INDIVIDUAL SETTINGS

The PX136 module has the individual settings option. It allows to ascribe a discretionary DMX address to every output channel. The simplest example is controlling the one-coloured LEDs brightness connected to all the outputs. In such a case you need to ascribe one DMX address to all the channels, that causes all the outputs can be controlled with one slider only.

To define the individual settings:

1. Enter the individual settings menu (the *Ind* abbreviation stands for this menu).
2. With "next" or "previous" key choose the first input settings (*Ad1*).
3. With "next" or "previous" key set the required value. You can choose from range from 1 to 512.
4. Set the addresses for the second and third output.

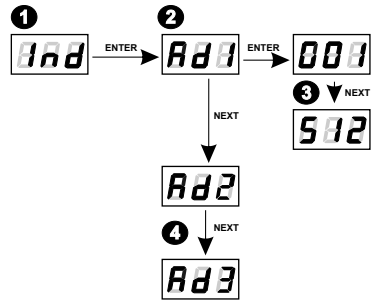

11. REACTION TO DMX SIGNAL INTERRUPTION

This feature is used not only to protect the installation from DMX signal interruption, but also to control the LEDs without the external controller. After the feature is activated, when the DMX signal is not present, the module will realize the selected function independently. When the DMX signal is connected again, the module stops playing the function and starts working according to the commands transmitted through the DMX line.

To activate the NO SIGNAL feature you must enter the *noS* option.

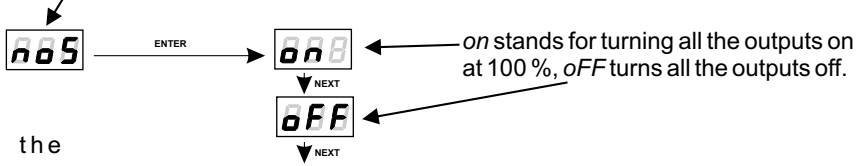

on stands for turning all the outputs on at 100 %, *oFF* turns all the outputs off.

To define the scenes by your own you must enter the *ScOpt* option.

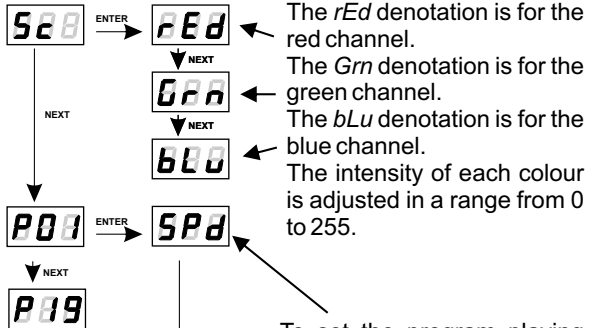

The *rEd* denotation is for the red channel.

The *Grn* denotation is for the green channel.

The *bLU* denotation is for the blue channel.

The intensity of each colour is adjusted in a range from 0 to 255.

You can also use the 19 factory-defined sequences. You may adjust the playing speed and step-to-step fading smoothness for each program.

To adjust the program's steps fading speed in a required program's bookmark press the "enter" key. With the "next" or "previous" key set the *FAd* parameter and press "enter". Adjust the fading speed from 0 (immediate step-to-step change) to 100 (change completely smooth) with "next" or "previous" key. Confirm your settings by pressing "enter".

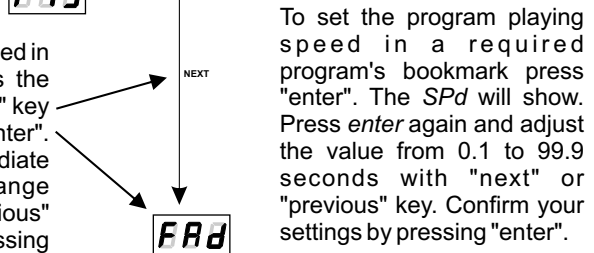

To set the program playing speed in a required program's bookmark press "enter". The *SPd* will show. Press *enter* again and adjust the value from 0.1 to 99.9 seconds with "next" or "previous" key. Confirm your settings by pressing "enter".

12. PROGRAMS' DESCRIPTION

Tables below show values for particular output channels - R, G, B - in programs from 1 to 19 (P01 - P19). 255 stands for maximal output brightness, 127 for 50% and 0 for channel blackout.

		P01	P02	P03	P04	P05	P06	P07	P08	P09	P10
step 1	R	255	0	0	0	255	255	0	255	0	255
	G	0	0	0	0	0	0	255	0	255	0
	B	0	255	0	0	0	0	255	0	0	0
step 2	R	0	0	255	0	255	255	255	0	0	0
	G	255	255	0	0	255	0	0	255	0	0
	B	0	0	0	255	0	255	255	0	255	255
step 3	R	0	255	0	0	0	0	255			
	G	0	0	0	0	255	0	255			
	B	255	0	0	0	0	255	0			
step 4	R			0	0	0	0				
	G			255	255	255	255				
	B			0	0	255	255				
step 5	R			0	0	0	0				
	G			0	0	0	255				
	B			0	0	255	0				
step 6	R			0	255	255	255				
	G			0	0	0	255				
	B			255	0	255	0				

		P11	P12	P13	P14	P15	P16	P17	P18	P19
step 1	R	0	0	0	255	0	0	0	0	255
	G	0	0	0	0	255	0	127	0	0
	B	0	0	0	0	0	255	255	0	0
step 2	R	255	0	0	255	127	127	127	255	0
	G	0	255	0	127	255	0	255	255	255
	B	0	0	255	0	0	255	127	255	255
step 3	R				255	0	0	255		
	G				0	255	0	127		
	B				0	0	255	0		
step 4	R				255	0	0	127		
	G				0	255	127	0		
	B				127	127	255	127		

13. BRIGHTNESS CONTROL FREQUENCY

Frq feature allows to set the basic LEDs control frequency. This feature, as well as the frequency correctio (refer to chapter 14 of the present manual) is particularly helpful in the TV industry applications by the use of "flicker free" technology. This technology allows to avoid an unpleasant image flashing effect caused by lack of LEDs control signal synchronization. The table below shows the frequency values corresponding to *Frq* parameter values.

For *Frq* values between 0 and 2 the PWM fulfillment of the LED is exponential:

0	244.1 Hz - 488.3 Hz	(SYn increment = 1.9 Hz)
1	488.3 Hz - 976.6 Hz	(SYn increment = 3.81 Hz)
2	976.6 Hz - 1.953 kHz	(SYn increment = 7.63 Hz)

For *Frq* values between 3 and 5 the PWM fulfillment of the LED is linear:

3	1.953 kHz - 3.9 kHz	(SYn increment = 15.26 Hz)
4	3.9 kHz - 7.81 kHz	(SYn increment = 30.52 Hz)
5	7.81 kHz - 15.62 kHz	(SYn increment = 122.1Hz)

To set the range of a basic frequencies:

1. Enter the *Frq* menu.
2. With "next" or "previous" keys select the required value.

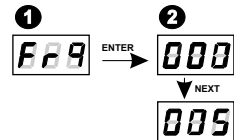

14. CONTROL FREQUENCY FINE TUNING

SYn feature allows to tune precisely the frequency selected in *Frq* menu. It is adjusted in a range between 0 and 128 - when *SYn* parameter is set to 0, the frequency adopts the minimal value in a particular range, when *SYn* is set to 128, the frequency adopts a maximal value in a range.

To precisely tune the previously selected basic frequency:

1. Enter the *SYn* menu.
2. With "next" or "previous" keys set the required value.

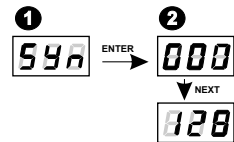

15. CONNECTIONS SCHEME

Because the active-type DMX in PX136 module is applied, there is no need to employ the terminators.

Such a solution allows to connect any number of PX136 drivers to a DMX controller.

The connections have to be made with wires of appropriate gauge.

The proper connection lowers the risk of damaging the driver and improves its reliability.

For DMX signal connection use the shielded conductors only.

The controlled LEDs can be connected with 6 or 4 wires. In case of 4-wire connection the common lead must be "⏏".

15.1. 6-wire connection

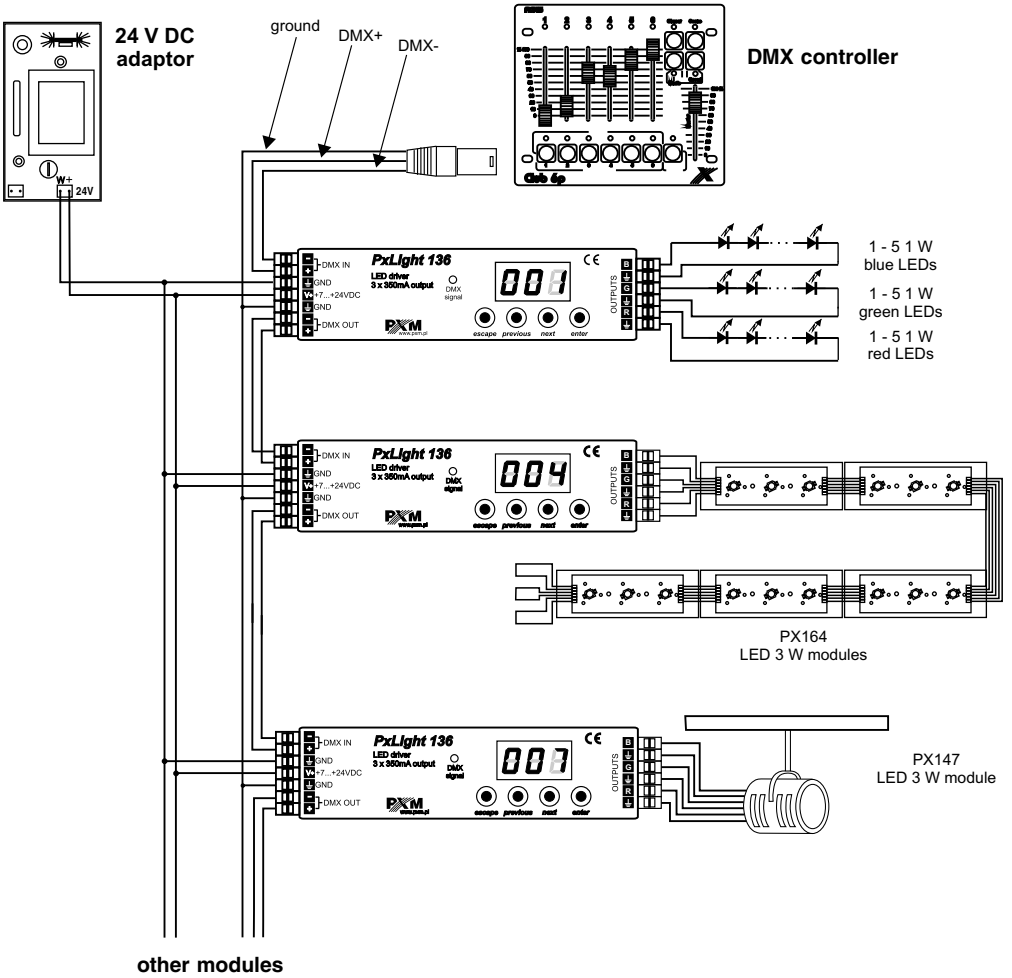

15.2. 4-wire connection

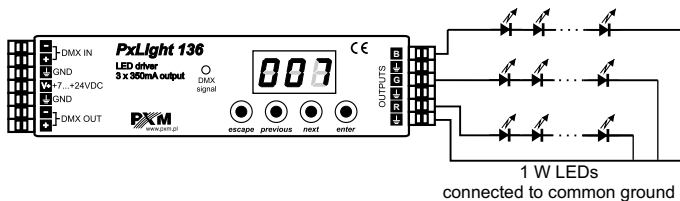

16. PROGRAMMING

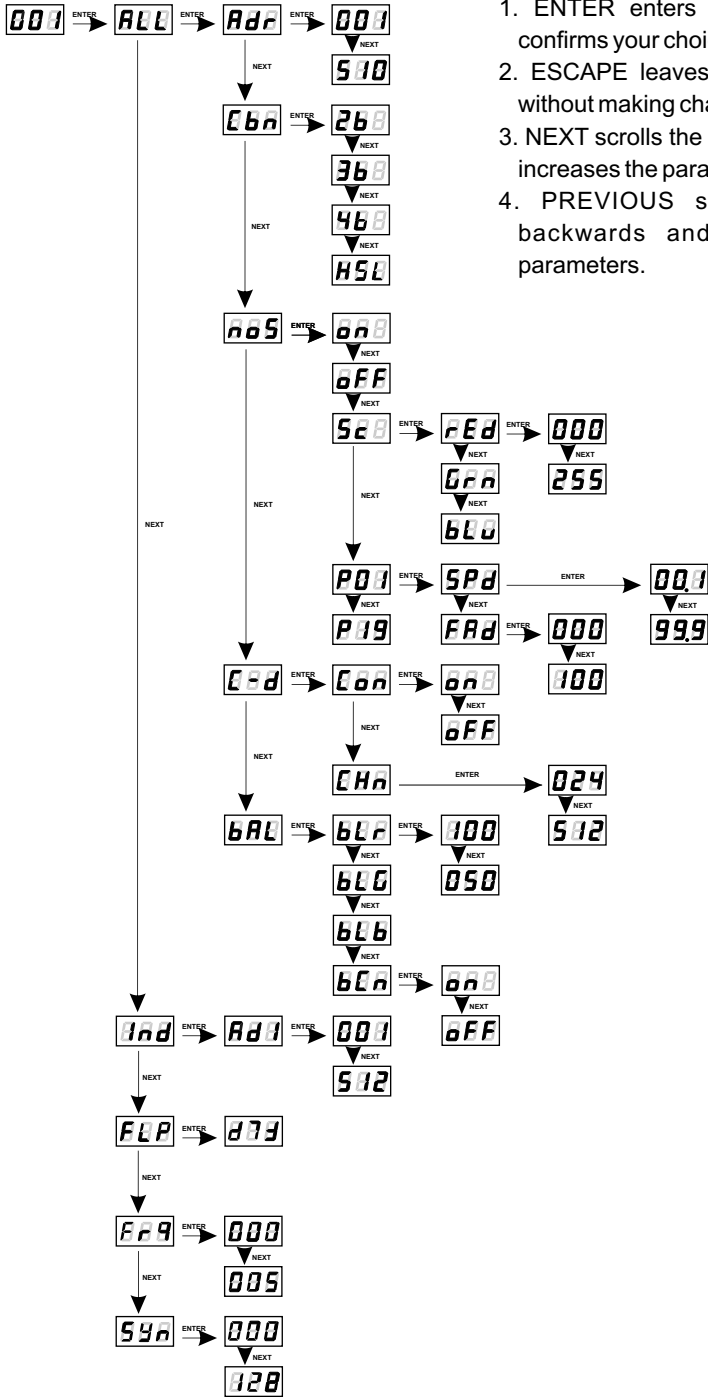

REMARKS:

1. ENTER enters the submenu and confirms your choice.
2. ESCAPE leaves the current menu without making changes.
3. NEXT scrolls the menu forwards and increases the parameters.
4. PREVIOUS scrolls the menu backwards and decreases the parameters.

17. PxLink PROTOCOL

PxLink protocol, designed by PROXIMA s.c., allows to remotely program the lamps through the DMX line (eg. setting the DMX address for each lamp separately).

This feature is particularly helpful in inconvenient circumstances, for instance when the access to the lamp is burdensome (eg. because of the mounting place).

The PxLink protocol can be applied by proxy of a proper controller, as PX133 for instance.

PxLink is a registered trademark. (it's available only to 0.37 firmware)

18. DIMENSIONS

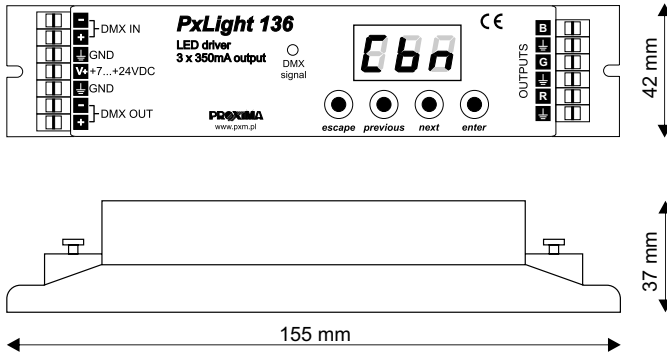

19. TECHNICAL SPECIFICATION

- | | |
|-------------------------------|---|
| - DMX channels | 512 |
| - power supply | 12V DC for 1 or 2 LEDs
24V DC for 3, 4 or 5 LEDs |
| - current consumption | 22W (at 15 1W LEDs) |
| - no-load current consumption | 100 mA |
| - output channels number | 3 |
| - control accuracy | 16 bit |
| - programmable scenes | 1 |
| - built-in programs | 19 |
| - outputs load capacity | 350 mA / channel |
| - output sockets | quick connectors |
| - PxLink | yes(available to 0.37 firmware) |
| - MASTER mode | yes |
| - dimensions: | |
| - lenght | 155mm |
| - width | 42 mm |
| - weight | 37 mm |





ul. Przemysłowa 12
30-701 Kraków, Poland

tel: +48 12 626 46 92
fax: +48 12 626 46 94

e-mail: info@pxm.pl
http://www.pxm.pl

DECLARATION OF CONFORMITY according to guide lines 89/336/EWG

Name of producer: PXM s.c.

Address of producer: ul. Przemysłowa 12
30-701 Kraków

declares that the product:

Name of product: **LED Driver 3 x 350 mA**

Type: **PX136**

answers the following product specifications:

EMC: **PN-EN 55103-1**
PN-EN 55103-2

Additional informations:

The DMX-512 output must be shielded and the shielding must be connected to the ground responding to the DMX connectors.

Kraków, 01.06.2006

PXM S.C.
Danuta i Marek Żupnik
30-701 Kraków, ul. Przemysłowa 12
NIP 677-002-54-53

Marek Żupnik M.Sc.