

PX215

LED Driver
3 x 350mA / 48V

MANUAL



CONTENTS

<u>1. General description.....</u>	3
<u>2. Safety conditions.....</u>	3
<u>3. Model description.....</u>	4
<u>4. Connection diagram.....</u>	4
<u>5. DMX signal connection.....</u>	6
<u>6. Meaning of displayed messages.....</u>	6
<u>7. Programming of group parameters.....</u>	9
<u>7.1 Setting of DMX address.....</u>	9
<u>7.2 Operation mode.....</u>	9
<u>7.3 Response to the lack of DMX signal.....</u>	11
<u>7.4 Description of the programs.....</u>	12
<u>7.5 MASTER / SLAVE function.....</u>	13
<u>7.6 White balance.....</u>	14
<u>7.7 The smoothing function.....</u>	14
<u>8. Programming of individual parameters.....</u>	15
<u>9. Light control frequency.....</u>	15
<u>10. Screen timeout.....</u>	15
<u>11. Temperature limits and sensor failure.....</u>	16
<u>12. Additional functions.....</u>	17
<u>12.1 Rotation of the display.....</u>	17
<u>12.2 Default settings and memory error.....</u>	17
<u>13. RDM description of available parameters.....</u>	19
<u>14. Programming.....</u>	23
<u>15. Dimensions.....</u>	24
<u>16. Technical data.....</u>	24
<u>Declaration of conformity.....</u>	25

Manufacturer reserves the right to make modifications in order to improve device operation.

1. GENERAL DESCRIPTION

The PX215 driver is intended for LEDs control. The built-in DMX signal receiver allows to control 3 channels (R, G, B) through DMX protocol. The wide range of feeding voltage and high load capacity allow to control great number of LEDs.

The PX215 can be controlled with DMX signal or operate independently. In such case the user has at disposal a fully programmable scene and 18 factory-defined sequences, for these the user can adjust the playing speed and step-to-step fading smoothness.

The driver makes it possible to set the frequency of the PWM control signal ("flicker free" technology). Thanks to this, it is particularly useful in applications for the television industry.

Because LEDs from the RGB series often differ in parameters, it may cause problems getting a white colour from the RGB channels. That is why PX215 is equipped with a feature known as "white balance". Thanks to it you can adjust the color control of each module, with full power to achieve the color white. What's more, this feature allows to some extent also adjust the color temperature of white color.

In addition, the driver is equipped with a temperature sensor output and support of RDM protocol (starting from serial number 14290020). The temperature sensor support enables the reduction of power diodes according to the temperature measured in the lamp.

2. SAFETY CONDITIONS

The PX215 LED Driver 3 x 350 mA / 48V is a device powered with safe voltage up to 48V; however, during its installation and use the following rules must be strictly observed:

1. The device may only be connected to 12 - 48V DC (stabilized voltage) with current-carrying capacity compatible with technical data.
2. All the conductors should be protected against mechanical and thermal damage.
3. In the event of damaging any conductor, it should be replaced with a conductor of the same technical data.
4. Connection of DMX signal can only be made with shielded conductor.
5. All repairs and connections of outputs or DMX signal can only be made with cut off power supply.
6. The PX215 should be strictly protected against contact with water and other liquids.
7. All sudden shocks, particularly dropping, should be avoided.
8. The device cannot be turned on in places with humidity exceeding 90%.
9. The device cannot be used in places with temperature lower than 2°C or higher than 40°C.
10. Clean with damp duster only.

3. MODEL DESCRIPTION

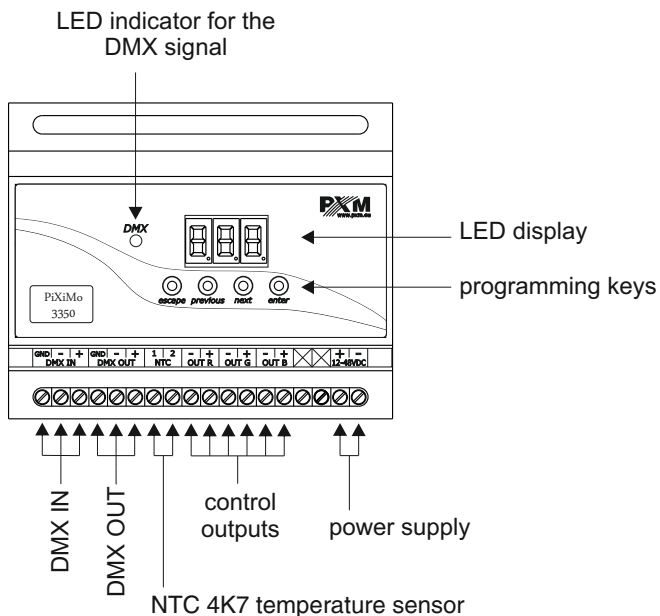

4. CONNECTION SCHEME

Example connection the PX215 driver to the LED lamp:

- the cables should be connected with the correct order of colors,
- LEDs should be connected only in series,
- controlled LEDs can be connected using two conductors only, i.e. two per channel,
- the number of serially connected LEDs depends on the driver and supply voltage.

a) RGB lamp connection

b) Monochromatic lamps connection

350 mA power supply

Driver LED	Power supply	Quantity of powered lamps
PX215	PY417-12V	1-3
	PY415-24V	4-6
	PY421-48V	7-12

350 mA power supply

Driver LED	Power supply	Quantity of powered lamps
PX215	PY417-12V	3
	PY415-24V	6
	PY421-48V	12

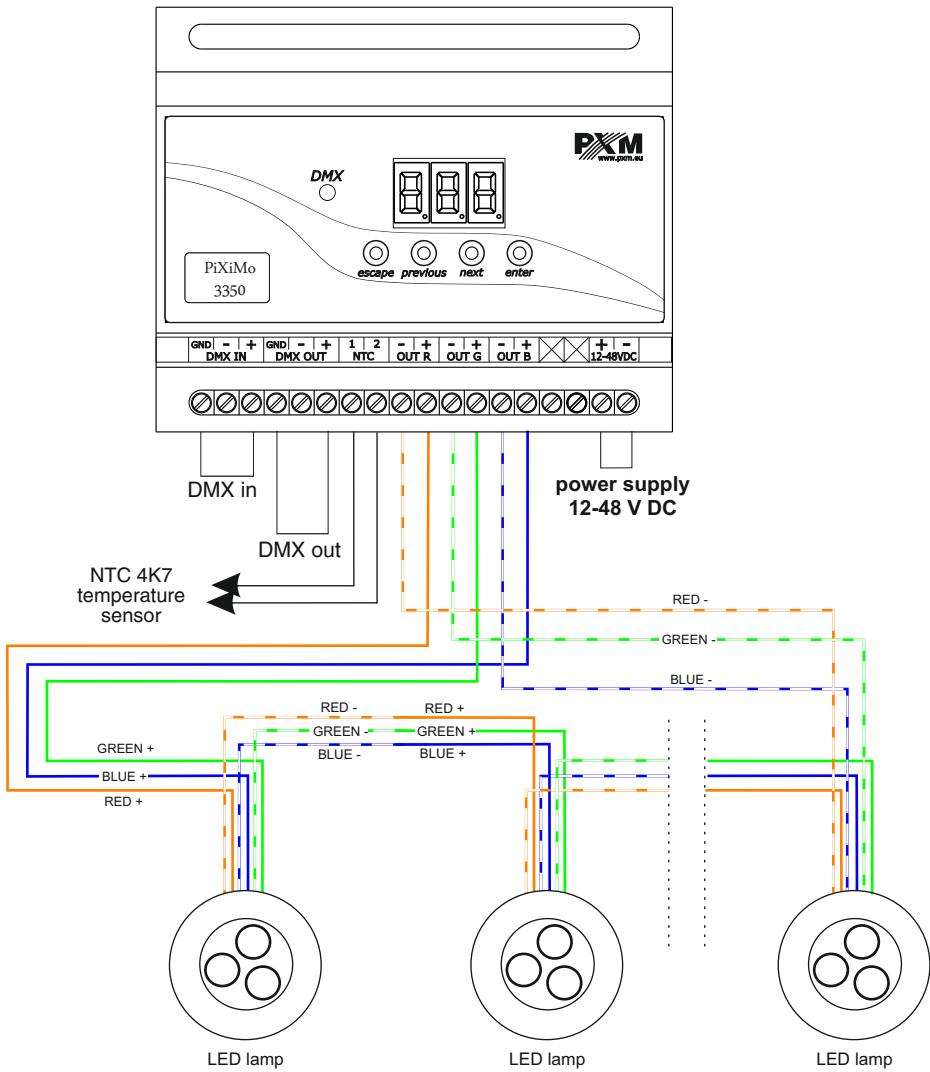

NOTE:
 Temperature measurement is correct only when
 the NTC 4K7 sensor is connected to the driver input

5. CONNECTING DMX SIGNAL

PX215 must be connected to DMX line in series. This means that DMX IN terminals in the device must be provided with the driving cable, and then from DMX OUT connector the driving cable must be provided to other DMX receivers.

If PX215 is the last device in DMX line, DMX Out terminals must be provided with the terminator – resistor of 120 Ω between pins “+” and “-”

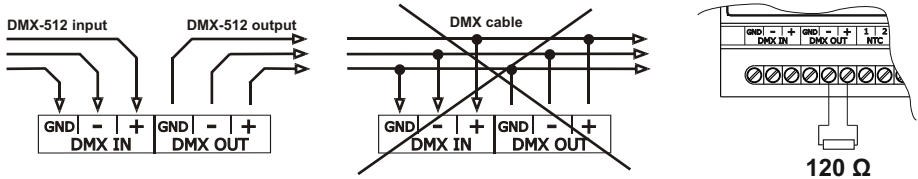

6. DESIGNATION OF DISPLAYED MESSAGES

- 000** DMX address of a device - a basic item in the MENU
- 000** setting parameters for all channels simultaneously
- 100** setting parameters for each channel individually
- 000** DMX address setting
- 000** control method selection (RGB, LIGHTNESS / COLOUR, etc.)
- 000** no DMX signal response method selection
- 000** MASTER / SLAVE mode settings
- 200** LIGHTNESS /COLOUR control mode
- 300** RGB control mode
- 300** RGB Dimmer control mode
- H00** HSL control mode - HUE / SATURATION / LIGHTNESS
- 000** effect control mode
- 000** all outputs at 100%
- 000** all outputs off

528	scene
P17	programme no. 17
E2E	shorted thermistor
A11	DMX address settings for first channel
088	MASTER mode on / off
088	number of channels being sent in the MASTER mode
682	white colour balance setting
602	red balance
600	green balance
606	blue balance
608	white colour balance on / off
5P8	program playback speed
F88	level of steps change smoothness in the program
FED	red colour during scene programming
088	green colour during scene programming
600	blue colour during scene programming
E2E	memory error message
8F1	restore default device settings menu
5E8	smooth function between transitions of different values
885	disable of smooth function
P2P	smoothing linearly between packets of DMX signal
E2E	power backoff management menu according to the temperature
F89	frequency of PWM signals
502	switching on of the screen backlight
E80	smoothing in the time interval

880

function to limit power

828

value of the limit activation temperature

8H8

value of the maximum limit temperature

88C

current temperature

85H

the highest temperature recorded by the sensor

85L

the lowest temperature recorded by the sensor

888

temperature limit is switched off and it is not possible to read the following temperatures: maximum, minimum, and current or when a mode which does not use all channels is set, and unused channels will have the address of the channel

4E5

approval of changes

870

thermistor open / no thermistor

7. PROGRAMMING OF GROUP PARAMETERS

Programming in this menu applies to all channels. After selecting **ALL** in the main menu confirm your selection by pressing the "enter" key, followed by "next" or "previous", and select the parameters you want to set:

- Adr** - DMX address of the device,
- Cbn** - Selection of the control method,
- noS** - Response of the device to the fading of the DMX signal,
- C_d** - MASTER/ SLAVE function,
- bAL** - White balance setting,
- Sth** - Transition smoothing between different values.

7.1. Setting of DMX address

Menu of the PX215 driver allows for setting the DMX address of the device depending on the mode of operation in the following range:

- 1 - 511 : two-byte mode **2b**
- 1 - 510 : three-byte mode **3b**
- 1 - 509 : four-byte mode **3bd**
- 1 - 510 : **HSL** mode (**H**ue, **S**aturation, **L**ightness)
- 1 - 506 : effect mode **EFF**

For example, for the **EFF** mode the module occupies seven consecutive DMX addresses; when setting the address to 506, the last channel is occupied by address 512.

All channels line up one behind the other, and we select the first of these channels. Each address programmed this way deletes previous individual settings of channels.

To set the DMX address:

1. Set the **Adr** function,
2. Using the "next" or "previous" buttons set the selected DMX address,
3. Confirm your selection by pressing "enter".

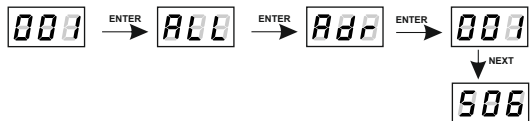

7.2 Operation mode

The PX215 driver can operate in the following modes: **EFF**, **HSL**, 4-channel, 3-channel or 2-channel. A description of the EFF mode is shown on the next page.

For the selected operating mode the following channels have the following settings:

2b mode – lightness and one of the 256 colours defined by a colour designer;

3b mode – three colours: R (red), G (green), B (blue);

3bd mode – three colours: R (red), G (green), B (blue), and the fourth channel includes the Dimmer function – dimming of all outputs;

HSL mode – operates on three channels which are responsible for colour, colour saturation and lightness, respectively;

EFF mode – a description of the *EFF* mode is shown below.



To select the operating mode:

1. Go to the **Cbn** function,
2. Using the "next" or "previous" buttons set the selected operating mode.
3. Confirm your selection by pressing "enter".

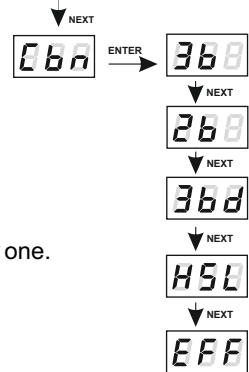

After changing the operating mode all the channels are set one by one.

Description guide of EFF mode settings

EFF mode (effect) channels description						
CHANNEL1 RED	CHANNEL2 GREEN	CHANNEL3 BLUE	CHANNEL4 – MODE	CHANNEL5 SPEED	CHANNEL6 FADE	CHANNEL7 BRIGHTNESS
-	-	-	< 0 - 7 > Program1	x	x	x
-	-	-	< 8 - 15 > Program2	x	x	x
-	-	-	< 16 - 23 > Program3	x	x	x
-	-	-	< 24 - 31 > Program4	x	x	x
-	-	-	< 32 - 39 > Program5	x	x	x
-	-	-	< 40 - 47 > Program6	x	x	x
-	-	-	< 48 - 55 > Program7	x	x	x
-	-	-	< 56 - 63 > Program8	x	x	x
-	-	-	< 64 - 71 > Program9	x	x	x
-	-	-	< 72 - 79 > Program10	x	x	x
-	-	-	< 80 - 87 > Program11	x	x	x
-	-	-	< 88 - 95 > Program12	x	x	x
-	-	-	< 96 - 103 > Program13	x	x	x
-	-	-	< 104 - 111 > Program14	x	x	x
-	-	-	< 112 - 119 > Program15	x	x	x
-	-	-	< 120 - 127 > Program16	x	x	x
-	-	-	< 128 - 135 > Program17	x	x	x
-	-	-	< 136 - 143 > Program18	x	x	x
-	-	-	< 144 - 151 > OFF	-	-	-
x	x	x	< 152 - 169 > Strobo 10%	x	-	x
x	x	x	< 170 - 199 > Strobo 20%	x	-	x
x	x	x	< 200 - 229 > Strobo 50%	x	-	x
x	x	x	< 230 - 255 > RGBD	-	-	x

- CHANNEL1 - red colour
- CHANNEL2 - green colour
- CHANNEL3 - blue colour
- CHANNEL4 - operating mode selection
- CHANNEL5 - speed settings (higher value - quicker changes)
- CHANNEL6 - fade settings (higher value - smoother transition)
- CHANNEL7 - lightness settings (higher value - stronger glow)

- character ("x") - possibility to control a given parameter of a selected mode
- character ("-") - no possibility to control a given parameter of a selected mode

7.3 Response to the lack of DMX signal

This function is used to protect the installation against fading of the DMX signal, and to control the LEDs without connecting an external controller. After it is activated, and if there is no DMX signal, the module will execute the selected function independently. Reconnecting the DMX signal will automatically stop the function being executed, and the module will again execute commands transmitted via the DMX line.

You can also use the 18 preset programs. It is also possible to set the playback speed and steps change smoothness in the program for each of them

to set the playback rate, press "enter" in a tab of a given programme. You will be able to change the **SPd** value (possibly in the range from 0.1 up to 99.9 seconds) after pressing "enter" again.

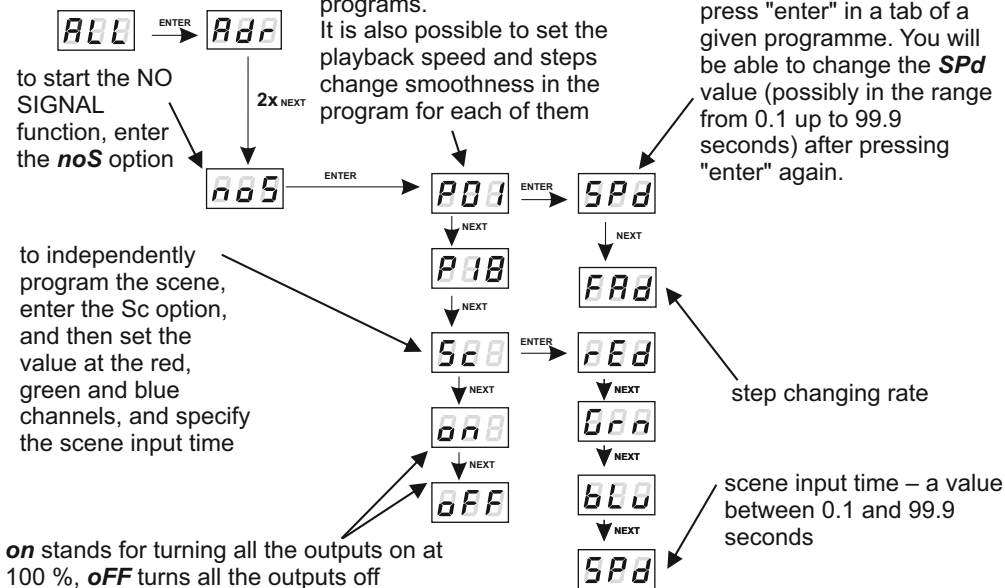

The red channel (**rEd**), the green channel (**Grn**), and the blue channel (**bLu**) – the intensity of each of them is controlled within the range of 0 - 255.

To change the step change rate, press "enter" on the tab of the selected program. Use the "next" or "previous" buttons to set the **Fad** parameter. Then, press the "enter" button and enter the chosen value between 0 (abrupt transition) to 100 (smooth transition).

To confirm the changes made in the "no DMX signal response" settings press the "enter" button.

7.4 Description of the programs

Tables below show values for particular output channels - R, G, B - in programs from 1 to 18 (P01 - P18). 255 stands for maximal output brightness, 127 for 50% and 0 for channel blackout.

		P01	P02	P03	P04	P05	P06	P07	P08	P09	P10
step 1	R	255	0	0	0	255	255	0	255	0	255
	G	0	0	0	0	0	0	255	0	255	0
	B	0	255	0	0	0	0	255	0	0	0
step 2	R	0	0	255	0	255	255	255	0	0	0
	G	255	255	0	0	255	0	0	255	0	0
	B	0	0	0	255	0	255	255	0	255	255
step 3	R	0	255	0	0	0	0	255			
	G	0	0	0	0	255	0	255			
	B	255	0	0	0	0	255	0			
step 4	R			0	0	0	0				
	G			255	255	255	255				
	B			0	0	255	255				
step 5	R			0	0	0	0				
	G			0	0	0	255				
	B			0	0	255	0				
step 6	R			0	255	255	255				
	G			0	0	0	255				
	B			255	0	255	0				

		P11	P12	P13	P14	P15	P16	P17	P18
step 1	R	0	0	0	255	0	0	0	0
	G	0	0	0	0	255	0	127	0
	B	0	0	0	0	0	255	255	0
step 2	R	255	0	0	255	127	127	127	255
	G	0	255	0	127	255	0	255	255
	B	0	0	255	0	0	255	127	255
step 3	R				255	0	0	255	
	G				0	255	0	127	
	B				0	0	255	0	
step 4	R				255	0	0	127	
	G				0	255	127	0	
	B				127	127	255	127	

7.5 MASTER/SLAVE function

The PX215 module has a built-in DMX-512 receiver and it can be controlled from any desktop operating in this standard. Additionally, it comes with a programmable response function to no DMX signal (**noS**). With 18 built-in factory programmes, it is possible to get effects without an external controller.

In larger installations, several PX215 modules implementing the same programme cannot provide full synchronization of playback. This is why PX215 has been equipped with the MASTER function. When the function is enabled, the module changes from the DMX receiver into a signal transmitter, and sends executed programmes to other modules (which must be set as SLAVE). With this solution, precise synchronization is possible in even very large installations.

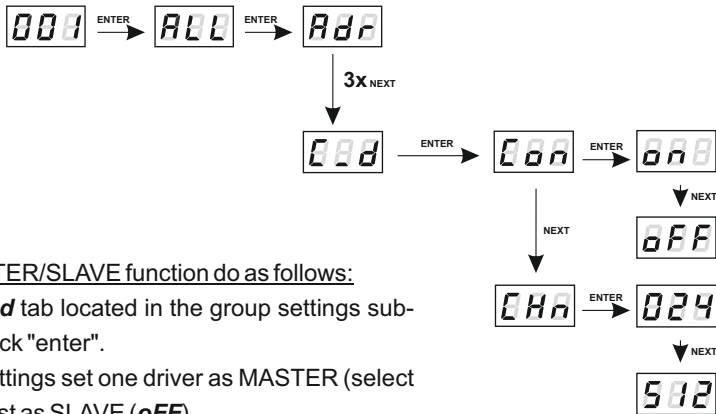

To set the MASTER/SLAVE function do as follows:

1. Go to the **C_d** tab located in the group settings sub-category and click "enter".

2. In the Con settings set one driver as MASTER (select "**on**") and the rest as SLAVE (**oFF**)

Setting the MASTER function will be signalled by rapid blinking of the LED.

3. In the CHn settings, the user specifies the number of outgoing DMX channels, and this is possible in the range of 24 - 512.

NOTE:

PX215 sends three channels (R, G, B) repeated several times on consecutive DMX channels.

7.6 White balance

The white balance function is used to prevent problems that may arise when the white colour is present in LED lamps from the RGB series. This may be caused by the use of LEDs with different technical parameters. Using this option, you can select the right colour temperature for full control of all three outputs (white colour).

001 → ENTER → ALL → ENTER → Adr

To set the white balance:

1. Go to the **Adr** tab located in the group settings sub-category, click "enter".

2. For each channel:

bLr - red colour

bLG - green colour

bLb - blue colour

select an appropriate value between 0 and 100

3. To confirm or reject pre-selected values, go to the next

bCn tab and select:

on - to turn on the white balance

oFF - to turn off the white balance.

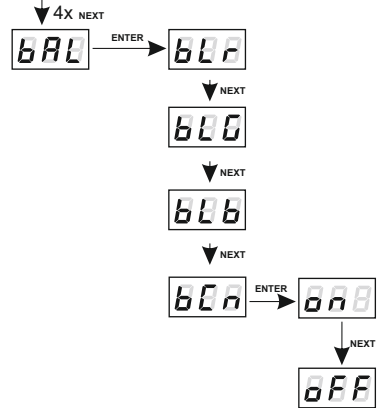

7.7 The smoothing function

The PX215 device is equipped with a smoothing option. If this option is enabled, it allows for smooth transitions between successive DMX values that are sent to the lamp (changes in lightness and colour) without visible abrupt changes. This prevents the occurrence of "vibrations" of light in lighting installations. Two successive DMX values sent to the lamp are smoothed linearly between packets of DMX signal for the selected **P2P** option or within a time interval set in the **tim** menu. (**EEA**).

The enabled smoothing function may slightly slow down the lamp response rate to DMX signal changes; therefore, this option can be disabled. To disable smoothing, select the **diS** parameter and confirm the selection by pressing "enter".

001 → ENTER → ALL → ENTER → Adr

Time smoothing (**tim**) allows you to change the time parameter in which successive, variable values of the DMX signal sent to the lamp are smoothed between each other. The user can set the smoothing time using the "previous" and "next" buttons between the minimum value of 10 [ms], and the maximum value of 999 [ms].

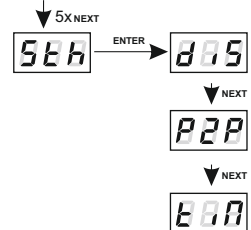

8. PROGRAMMING OF INDIVIDUAL PARAMETERS

The programming of individual parameters allows for assigning any DMX address to each output channel. The simplest example is to control the lightness of LEDs of the same colour plugged into all output channels of the driver.

In this situation, assign the same address (e.g. 1) to channels from 1 to 3, and now using one slider on the control panel or changing one DMX value we will trigger a reaction on each of the three channels.

To program individual settings:

1. Go to the **Ind** tab.
2. Go to the settings of the first output marked as **Ad1**.
3. Use the "next" or "previous" buttons to set a value from 1 up to 512.
4. Set the address for the remaining outputs (by default successive values are set from value 1 for the first output to value 7 for the seventh).

If a mode which does not use all channels is set, the unused channels have addresses equal to 

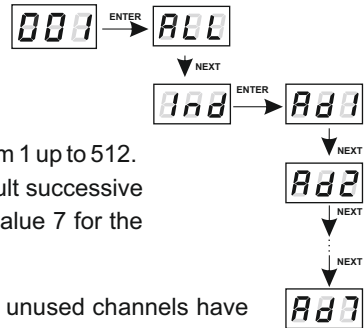

9. LIGHT CONTROL FREQUENCY

The **Frq** function allows for setting the base control frequency for the LEDs. This function is extremely useful in applications for the television industry. The use of "flicker free" technology enables you to avoid an unpleasant effect of screen flickering caused by too low frequency of the PWM signal that controls the LEDs.

The user has access to a frequency range of 366 Hz up to 1.5 kHz.

The frequency value in the upper range (i.e. 1.50 = 1.5 kHz) makes it possible to avoid the flickering effect visible in the video image.

To set the selected range of base frequencies:

1. Go to the **Frq** tab.
2. Using the "next" or "previous" buttons set the selected value.
3. Confirm your selection by pressing "enter".

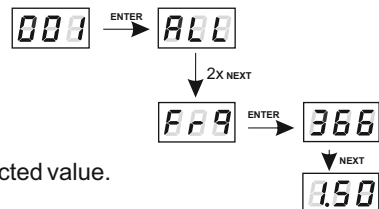

10. SCREEN TIMEOUT

The device has been equipped with an option to turn off the LED display backlight. If the **Scr** option is activated, the display will be turned off after 1 minute of idle work (keys are not used). The device continues to work without interfering with other parameters. To restore backlight, use any key.

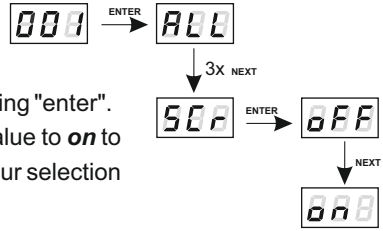

To activate the backlight dimming function:

1. Go to the **Scr** tab and confirm your selection by pressing "enter".
2. Use the "next" or "previous" buttons to change the value to **on** to activate the screen dimming function, and confirm your selection by pressing "enter".

Proceed in a similar way to disable this feature but then select **OFF**.

11. TEMPERATURE LIMITS AND SENSOR FAILURE

PX215 has been equipped with a function that limits the output power depending on the temperature value read using the external sensor mounted in the lamp. This allows for programming a temperature value which, if reached, limits the power or disables the lamp supplied by the driver. The product is designed to work only with the NTC 4K7 type thermistor.

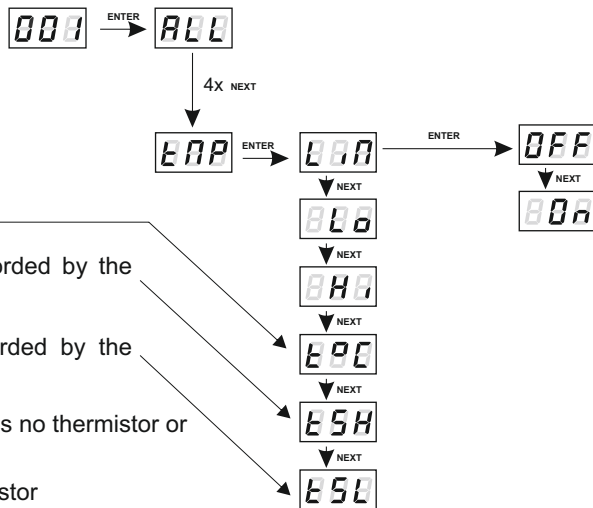

current temperature

the highest temperature recorded by the sensor

the lowest temperature recorded by the sensor

message **EPC** means there is no thermistor or the thermistor is open

message **ESH** closed thermistor

message **000** indicates that the temperature limit (**Lim**) has not been enabled

Available temperature limits:

- Lo** - value of the limit activation temperature; it can be set in the range from 30°C up to 60°C.
- Hi** - value of the maximum limit temperature; set in the range of 70-90°C.

The power limit between the **Lo** and **Hi** values occurs linearly as shown in the diagram on the next page.

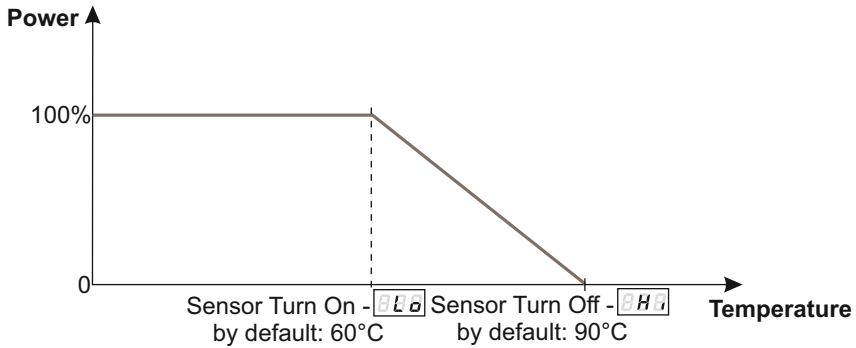

If this function is activated and the temperature sensor is incorrectly connected or there is no sensor, the driver displays a relevant message – **[EPD]** at the current temperature location, and instead of the first DMX address, i.e. at the very beginning of the menu. To disable the message, connect an appropriate sensor or disable the temperature limit.

12. ADDITIONAL FUNCTIONS

PX215 has additional functions: rotation of the display and default settings restoration; what is more, the driver signals a built-in memory error.

12.1. Display flip (old FLP feature)

If necessary, the user can rotate the display without turning of the entire device. To do this, hold down simultaneously for approx. 3s two middle buttons (previous and next).

NOTE: In addition to the display this feature turns also the order of the keys.

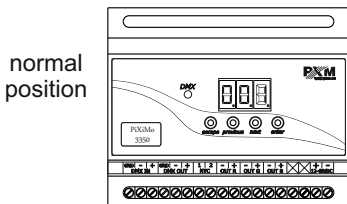

normal position

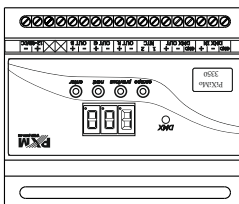

flipped display

To restore the default setting hold once again the middle keys for approximately 3 seconds.

11.2. Default settings and memory error

The device has been equipped with an option to restore default settings. To use this option you must disconnect PX215 from power supply. Before re-applying the power, press and hold the "previous" button. After turning on, the screen of the device shows a **dFI** message (during the power-on until the display shows the **dFI** button the "previous" button must be pressed).

Accepting this message **dFI** by pressing the „enter” key restores default settings. It is also possible to exit this menu without returning to default settings by pressing the „escape” button.

PX215 default settings are as follows:

- driver operating mode – RGB (3b - 3-byte)
- DMX address – 1
- no signal operating mode – programme 1,
- master mode – disabled,
- number of outgoing DMX channels – 128,
- White Balance – off,
- smoothing function – off.

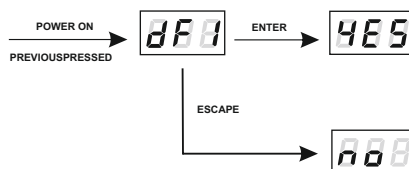

Err message - memory error

The device is equipped with a built-in memory work control function.

If there are problems with the memory operation, on the PX215 display the **Err** message appears **Err** - memory error.

In this situation, select the *enter* button. The device will reload the default configuration and upload it to the memory. If after this operation, the **Err** message remains on the screen, the memory is permanently damaged and the unit must be sent to the service point.

13. RDM DESCRIPTION OF AVAILABLE PARAMETERS

The PX215 supports the RDM protocol. DMX protocol allows only of a one-way data transmission, while its extension the RDM protocol can transmit information in two directions. This makes possible to simultaneously send and receive information, and hence the possibility of monitoring activities of the compatible devices. Thanks to RDM some available settings of compatible devices may be programmed using this protocol.

Below there is a list of RDM parameters supported by PX215:

Parameter name	PiD	Description
PARAMETER_DESCRIPTION	0x0051	description of additional parameters
DEVICE_INFO	0x0060	information concerning the device
SOFTWARE_VERSION_LABEL	0x00C0	firmware version of the device
DMX_START_ADDRESS *	0x00F0	DMX starting address of the device, minimum value: 1, maximum value: 512. According to the RDM standard, for device whose footprint is 0, the value of this parameter may be 65535 and then it is not possible to change the initial address settings for the entire device, but only for sub-devices.
IDENTIFY_DEVICE *	0x1000	device identification, Two states are possible: identification is off (0x00 value) and identification is on (0x01 value).
STATUS_MESSAGES	0x0030	information about device status
DEVICE_MODEL_DESCRIPTION	0x0080	device description, e.g. name
MANUFACTURER_LABEL	0x0081	manufacturer description, e.g. name
DEVICE_LABEL *	0x0082	additional device description, It is possible to enter an additional device description using up to 32 ASCII characters.
DMX_PERSONALITY	0x00E0	DMX operational mode
DMX_PERSONALITY_DESCRIPTION	0x00E1	description of individual operational modes
DEVICE_HOURS	0x0400	information concerning the working time of the device counted in hours
TEMPERATURE_LIMIT_ON/OFF	0x800E	temperature limitation activation for the temperature sensor connected to the driver, For 0 value, the function is not active; for 1 value, the function is active. Default value is 1.

Parameter name	PiD	Description
TEMPERATURE_THRESHOLD_LOW	0x800F	lower temperature value for which the temperature limitation is being activated
TEMPERATURE_THRESHOLD_HIGH	0x8010	upper temperature value for which the temperature limitation is active, i.e. the cut-off temperature for exits from the driver
BALANS_RED	0x8011	balance modulation value of red channel; Minimum value is 0 and maximum is 100 (the value corresponds to the percentage of modulation). For maximum value (100) LEDs operate at maximum lightness. Default value is 100.
BALANS_GREEN	0x8012	balance modulation value of green channel; Minimum value is 0 and maximum is 100 (the value corresponds to the percentage of modulation). For maximum value (100) LEDs operate at maximum lightness. Default value is 100.
BALANS_BLUE	0x8013	balance modulation value of blue channel; Minimum value is 0 and maximum is 100 (the value corresponds to the percentage of modulation). For maximum value (100) LEDs operate at maximum lightness. Default value is 100.
SMOOTH_DIS_0/P2P_1/TIM_2 *	0x801A	selection of the options concerning Smooth function; For 0 value, the smooth function is off; for 1 value, the smooth function operates in the Packet to Packet mode (P2P) and for 2 value, the smooth function operates in the time mode. Value 0 set by default – smoothing off.
SMOOTH_TIME *	0x801B	smoothing time for TIM (time) function selected in the above point; Unit expressed in [ms]. Minimum parameter value is 10 and maximum is 2000 [ms]. Default value is 200 [ms].

Parameter name	PiD	Description
NO_SIG_P1-18 SC_19 ON_20 OFF_21	0x801C	choice of work mode for No DMX signal; Minimal Value is 1, maximal 21. For values 1-18 menu allows to chose program from 1 to 18 which is played during no DMX signal detection. For the 19 value a scene saved in memory is set and for the 20 value all outputs are set to ON with maximum value. The value 21 sets to OFF all outputs during time with no DMX signal received. Default value is 21.
SCENE_RED *	0x801D	setting the value of the red channel for the scene; Minimum value is 0, maximum value is 255 (maximum lightness). Default value is 255.
SCENE_GREEN *	0x801E	setting the value of the green channel for the scene; Minimum value is 0, maximum value is 255 (maximum lightness). Default value is 255.
SCENE_BLUE *	0x801F	setting the value of the blue channel for the scene; Minimum value is 0, maximum value is 255 (maximum lightness). Default value is 255.
SCREENSAVER_ON/OFF *	0x8024	settings of screensaver (display backlight in PX215); With the 0 value display blanking is not active, the 1 value means screensaver active. Default value is 0.
PROGRAM_SPEED *	0x8025	programs playback speed settings (playing next steps of program); Minimum value is 1 and maximal 999 (maximum speed). By default it is set to 10. Value 1 represents 0,1s, and 999 - 99,9s.
PROGRAM_FADE *	0x8026	settings of smooth transition between following steps of a program; The minimum value is 0 (step transition) a maximum of 100 (transition completely smooth). The default value is 100.

Parameter name	PiD	Description
BALANCE ON/OFF *	0x8027	Turn on or off the balance of output channels; Value 0 is the channel balance off, value 1 is the channel balance on. Default value is 0.
PWM_FREQUENCY *	0x8028	LEDs refresh frequency; The minimum value is 366, and the maximum is 1500. The unit is [Hz] and the default value is 366.
SERIAL_NUMBER	0x8030	device serial number
DISPLAY_FLIP *	0x8038	inverting the meter display 180 degrees; The minimum value is 0, and the maximum is 1. The default value is 0.

* - parameter editable

15. DIMENSIONS

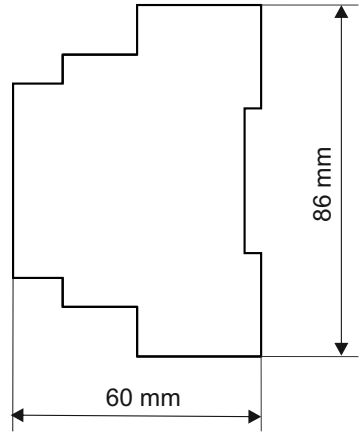
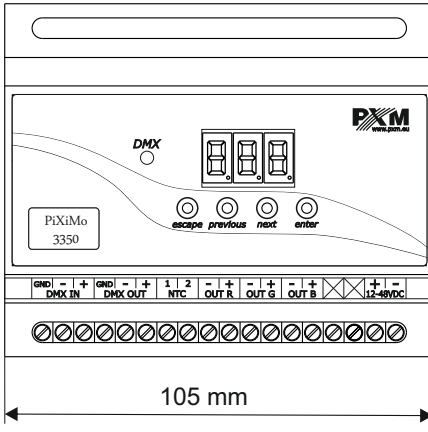

16. TECHNICAL SPECIFICATION

- DMX channels	512
- power supply	12V DC for 1, 2 or 3 LEDs 24V DC for 4, 5 or 6 LEDs 48V DC for 7, 8, 9, 10, 11 or 12 LEDs
- current consumption	1,1 A
- no-load power consumption	1 W
- output channels number	3
- control accuracy	16 bit
- programmable scenes	1
- built-in programs	18
- outputs load capacity	350mA / channel ^{+2%} _{-5%}
- output sockets	clamping screws
- DMX-RDM	yes (starting from 3.00 firmware)
- MASTER mode	yes
- dimensions:	
- width	105 mm
- heigth	86 mm
- depth	60 mm





ul. Przemysłowa 12
30-701 Kraków

tel: 12 626 46 92
fax: 12 626 46 94

e-mail: info@pxm.pl
<http://www.pxm.pl>

DECLARATION OF CONFORMITY according to guide line 2004/108/WE

Name of producer: PXM Marek Żupnik sp. k.

Manufacturer's address: ul. Przemysłowa 12
30-701 Kraków, Poland

We declare that our product:

Product name: **LED Driver 3 x 350mA / 48 V**

Product code: **PX215**

complies with the following standards:

EMC:
PN-EN 61000-4-2:2011
PN-EN 61000-6-1:2008
PN-EN 61000-6-3:2008

Additional informations: The DMX-512 output must be shielded and the shielding must be connected to the ground responding to the DMX connectors.

Marek Żupnik spółka komandytowa
30-701 Kraków, ul. Przemysłowa 12
NIP 677-002-54-53

Kraków, 15.12.2013

mgr inż. Marek Żupnik..