

PX392

PxArt+ 18

User manual



Table of Contents

1 Description.....	3
2 Safety conditions.....	4
3 Connectors and control elements.....	6
4 Information on version.....	6
5 DMX connection.....	7
5.1 GLOBAL Trac® GAC 600 adapter.....	7
5.2 The cross-section of the DMX GLOBAL Trac® Pulse Control.....	7
6 Control.....	8
6.1 Buttons.....	8
6.2 DMX signal.....	10
7 Cooperating with the PX277 configurator.....	11
7.1 Available parameters.....	11
7.2 The PxArt+ 18 menu diagram in PX277.....	13
8 RDM – available parameters.....	15
9 Connection scheme.....	17
10 Dimensions.....	18
11 Technical data.....	19

Manufacturer reserves the right to make modifications in order to improve device operation.

PXM Marek Żupnik sp.k.
Podłęże 654
32-003 Podłęże
BDO register number 000005972

tel. +48 12 385 83 06
mail: info@pxm.pl
www.pxm.pl

Rev.1-2
25.04.2019

1 Description

PxArt+ 18 is a professional LED illuminator designed for illumination of museum exhibitions or displays. Thanks to the application of the most modern semiconductor SSL LED light sources and advanced control electronics, a high class illuminator was created which meets very high requirements for museum and exhibition lighting. Its most important advantages include a complete lack of ultraviolet radiation emission, trace amounts of infrared radiation, a very high factor of CRI color capturing, smooth adjustment of colour temperature of emitted light, large brightness and small energy consumption.

The device features a base which allows for mounting it in GLOBAL Trac[®] Pulse Control bus bars, provided with an additional control line.

Two individual addresses allocated to each lamp allow for independent adjustment of its brightness and color temperature, regardless of the settings of other lamps. Through push buttons located on the lamp casing it is possible to operate it manually (e.g. in case of connecting the lamp to bus bars without a control line).

Highly-effective LEDs made by Osram Oslon[®] are used in the lamp with an efficient control system, through which the lamp emits small amounts heat.

The lamp casing renders it possible to change the direction of its beacon in two axes.

2 Safety conditions

Caution! Before installing, connecting and using the lamp you have to absolutely read this document.

The following symbols are used to underline important information on security on the product and in this manual.



Danger!
Risk of loss of life and health



Warning!
Fire hazard



Warning!
LED light emission, the risk of eye damage



Warning!
The risk of burns



Warning!
Read the instruction manual

Caution!

Do not look at the LEDs, LEDs can cause damage or eye irritation. Do not look at the light source with any optical devices that focus the light rays.



Light is harmful to unprotected eyes, can cause irritation, eye damage or even loss of eyesight.



While working outdoors in normal conditions, the housing unit can heat up to +65°C. Make sure that accidental contact with the device during use is impossible.



In case of improper usage of the product it may cause a risk of serious injury or death because of the threat of fire.

The PX392 device is powered directly from 230V power grid. Failure to comply with the safety rules may result in electric shock and may endanger the user's life. Therefore it is necessary to observe the following:

1. Installation should be performed by a person holding the appropriate qualifications, according to the instruction manual.
2. The electrical installation to which the lamp is to be connected must meet the safety requirements (the installation must be 3-wire and equipped with a residual current device).
3. All the conductors should be protected against mechanical and thermal damage.
4. In the event of damaging any conductor, it should be replaced with a conductor of the same technical data.
5. All repairs, should be made with cut off power supply.
6. Do not connect to the power supply to device with visible damage.
7. All sudden shocks, particularly dropping, should be avoided.
8. The device cannot be used in places with temperature lower than $+2^{\circ}\text{C}$ or higher than $+40^{\circ}\text{C}$.
9. Clear with damp cloth only.

3 Connectors and control elements

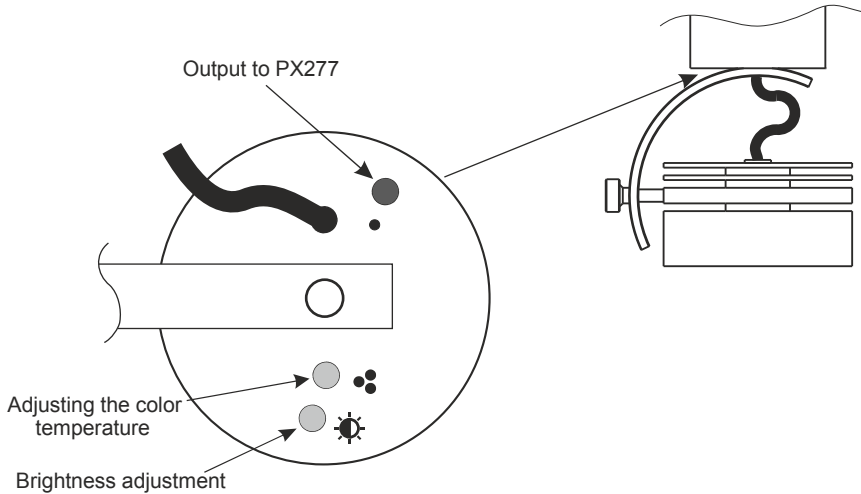

4 Information on version

Below is a description of the PX392 model designations with their explanation

PX392-XX-YY-Z

XX – beam angle:

10 – 10°

20 – 20°

30 – 30°

40 – 40°

EL – elliptical lenses

WW – Wall Washer

YY – colors of used LED

diodes:

MW – multi white

MC – colour (RGB)

Z – housing colors:

1 – white

2 – black

3 – gray

5 DMX connection

PxArt+ 18 is a device attached to the GLOBAL Trac® Pulse Control rail by using the GAC 600 adapter included in the kit.

5.1 GLOBAL Trac® GAC 600 adapter

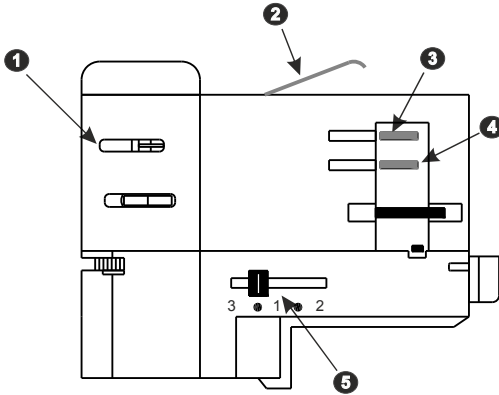

DMX contacts

- 1 DMX - (on the opposite side DMX +)

MAINS POWER SUPPLY

- 2 protective (⊕)
- 3 phase 1 (on the opposite side phase 2)
- 4 neutral (on the opposite side phase 3)
- 5 phase selection switch

5.2 The cross-section of the DMX GLOBAL Trac® Pulse Control

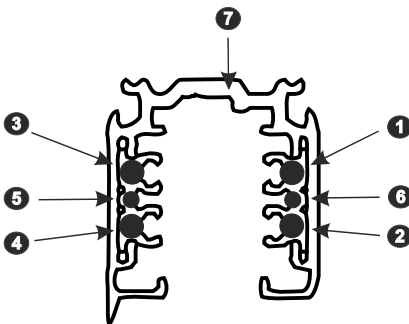

POWER SUPPLY

- 1 phase 2
- 2 phase 3
- 3 phase 1
- 4 neutral

DMX

- 5 DMX -
- 6 DMX +
- 7 mass (GND)

6 Control

6.1 Buttons

The lamp has been equipped with buttons which allow for changing the brightness level and colour temperature of light. The buttons have been placed at the bottom part of the junction box, above the lamp reflector. One button is responsible for one parameter.

Depending on a situation, the diode signals the following:

- start of the lamp – quick flickering of the diode for 2 seconds
- DMX signal receiving – slow flickering of the brightness adjustment button (1Hz frequency) in the first minute after receiving the DMX signal
- after the start of the lamp in case of the loss of DMX signal – diode lights (continuously) for 1 minute
- if the state of DMX signal changed (if there was no DMX signal and it returned, or vice versa) – diode signals it for 1 minute
- damage of the temperature sensor module – diode does not go out after 1 minute

To change the brightness or temperature color, press and hold down the appropriate control button. If during the brightness or colour temperature adjustment the button diode starts flickering, it means that the extreme value (minimum or maximum) has been reached. Then the direction of adjustment changes.

It is possible to change the adjustment direction without reaching extreme values. For example, while the lamp brightness is increased, release the control button for a moment. The diode will signal the change of adjustment direction. The pressing of the adjustment button again will cause the dimming of the lamp (brightness decrease).

While the lamp operates, the diode stays switched off (excluding situations mentioned above).

For lamps with RGB LEDs configuration, programming buttons available under the reflector have the following functions:

- colour temperature adjustment button – change of light color
- brightness adjustment button – change of the brightness value

6.2 DMX signal

The PX392 lamp can be controlled via two DMX channels.

- Channel 1 – color
- Channel 2 – brightness

Setting the lamp parameters:

	Value of the lamp parameter	Value of the DMX signal	
		Invert colour Turning off	Invert colour Turning on
Adjusting the color temperature (color)	4500K	255	0
	:	:	:
	3600K	128	128
	:	:	:
	2700K	0	255
Brightness adjustment	100%	255	
	:	:	
	50%	128	
	:	:	
	0%	0	

Flicker free – tuning the frequency of the control signal

Smooth – the smoothing function allows for smooth changes of brightness and color, without visible jerks, which prevents the effects of “vibrations” of light from occurring in lighting installations. Possible options to choose from:

- **Time** – smoothing in the set time interval
- **Off** – smoothing off
- **P2P** – linear smoothing between DMX packets

Smooth time – the smoothing function can be selected in the time interval from 10 to 2000ms

Default sett. – restoring factory settings in PX392:

- **Color address:** 1
- **Bright. address:** 2
- **Scene color:** 128
- **Scene bright.:** 128
- **Invert color:** Off
- **Flicker free:** On
- **Smooth:** Time
- **Smooth time:** 200ms

Lighting time – total lamp lighting time

Working time – total lamp operating time

Temp. min max – combination of the lowest and highest temperature recorded by the device

Current temp. – current temperature of the device

Serial Number – serial number of the device

Version – software version

7.2 The PxArt+ 18 menu diagram in PX277

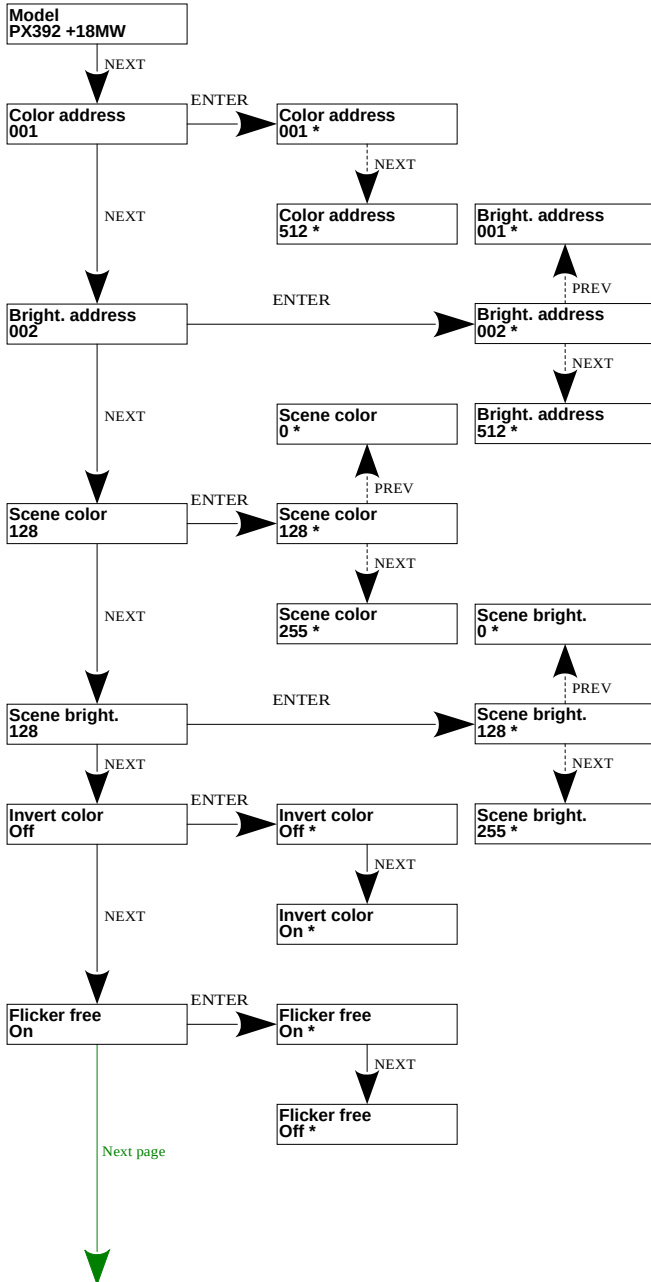

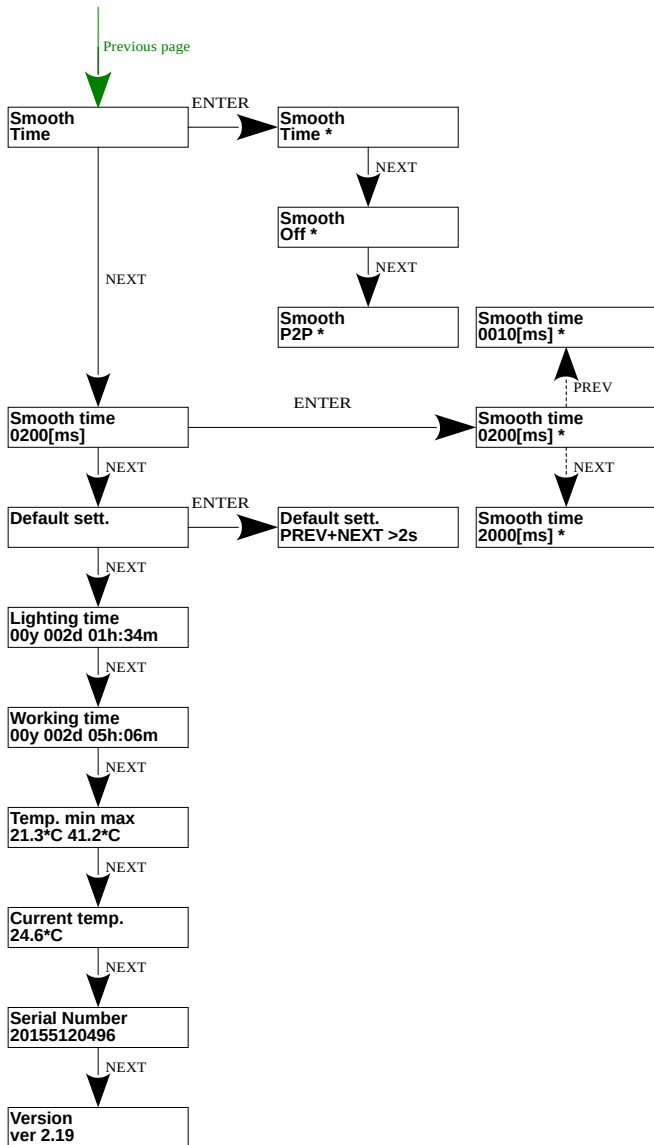

8 RDM – available parameters

The PX392 supports the DMX-RDM protocol. DMX protocol allows only of a one-way data transmission, while extension the RDM protocol can transmit information in two directions. This makes possibility of monitoring activities of the compatible devices. Thanks to RDM some available settings of compatible devices may be programmed using this protocol.

List of RDM parameters supported by the PX392:

Parameter name	PiD	Description
SUPPORTED_PARAMETERS	0x0050	all supported parameters
PARAMETER_DESCRIPTION	0x0051	description of additional parameters
DEVICE_INFO	0x0060	information concerning the device
SOFTWARE_VERSION_LABEL	0x00C0	firmware version of the device
DMX_START_ADDRESS *	0x00F0	DMX starting address of the device
IDENTIFY_DEVICE *	0x1000	device identification; Two states are possible: identification is off (0x00 value) and identification is on (0x01 value)
DEVICE_MODEL_DESCRIPTION	0x0080	device description, e.g. name
MANUFACTURER_LABEL	0x0081	manufacturer description, e.g. name
DEVICE_LABEL *	0x0082	additional device description; It is possible to enter an additional device description using up to 32 ASCII characters

Parameter name	PiD	Description
FACTORY_DEFAULTS	0x0090	device default settings
DMX_PERSONALITY *	0x00E0	DMX operational mode
DMX_PERSONALITY_DESCRIPTION	0x00E1	description of individual operational modes
SENSOR_DEFINITION	0x0200	information on the selected temperature sensor
SENSOR_VALUE	0x0201	information about sensors
DEVICE_HOURS	0x0400	total lamp operating time
LAMP_HOURS	0x0401	total lamp lighting time
SMOOTH_DIS_0/P2P_1/TIM_2 *	0x801A	selection of smoothing options
SMOOTH_TIME *	0x801B	smoothing time for the TIM function for the time smoothing option
SCENE_COLOR *	0x8021	color temperature settings, default value is 128
SCENE_BRIGHTNESS *	0x8022	brightness settings, default value is 128
FLICKER_FREE_ON/OFF *	0x8023	elimination of the flickering effect
SERIAL_NUMBER	0x8030	device serial number
INVERT_COLOR_ON/OFF *	0x8038	inversion of the light colour characteristics

* - editable parameter

9 Connection scheme

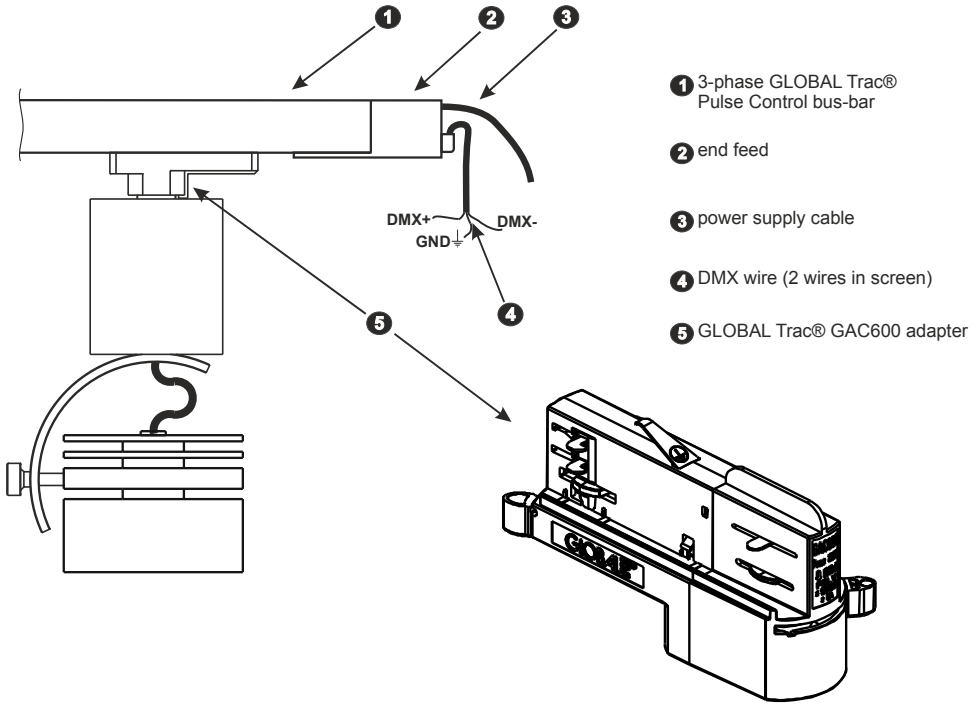

10 Dimensions

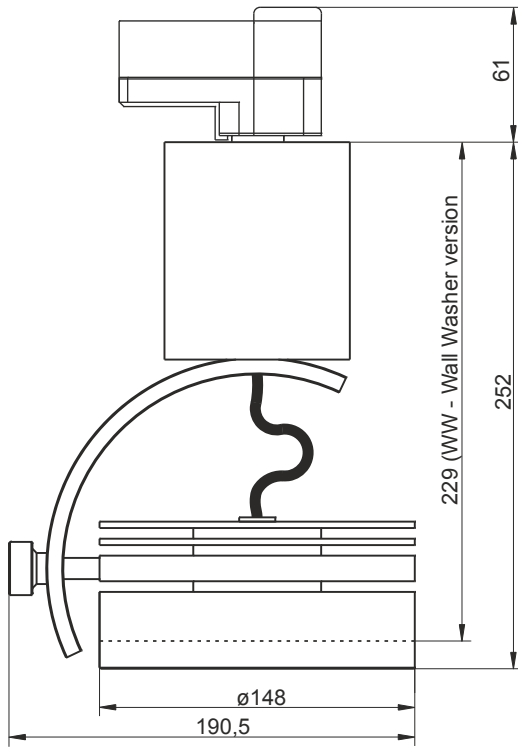

11 Technical data

type	PX392
power supply	230V AC
number of diodes	18
power consumption	25W
max. temperature rise housing	+30°C
luminous flux	1800lm
LEDs lifespan	50000h
beam angle	10°, 20°, 30°, 40°, EL (10 x 45°), WW* (50 x 110°)
colour temperature	2700 – 4500K (6000K on order)
range of brightness adjustment	0 – 100%
CRI index	min. 90
control	DMX, RDM
programmable scenes	1
mounting	GLOBAL Trac® Pulse Control
available housing colors	silver, black, white
weight	2.4kg
dimensions	height: 252mm diameter: 148mm

* - for a lamp equipped with WW (Wall Washer) optics the look of the reflector differs slightly (dimensions also)

DECLARATION OF CONFORMITY

PXM Marek Żupnik spółka komandytowa
Podłęże 654, 32-003 Podłęże

we declare that our product:

Product name: PxArt+ 18

Product code: PX392

meets the requirements of the following standards, as well as harmonised standards:

PN-EN 60598-1:2015-04

EN 60598-1:2015

PN-EN 62471:2010

EN 62471:2008

PN-EN 61000-4-2:2011

EN 61000-4-2:2009

PN-EN IEC 61000-6-1:2019-03

EN IEC 61000-6-1:2019

PN-EN 61000-6-3:2008

EN 61000-6-3:2007

and meets the essential requirements of the following directives:

2011/65/UE **DIRECTIVE OF THE EUROPEAN PARLIAMENT AND OF THE COUNCIL** of 8 June 2011 on the restriction of the use of certain hazardous substances in electrical and electronic equipment
Text with EEA relevance.

2014/30/UE **DIRECTIVE OF THE EUROPEAN PARLIAMENT AND OF THE COUNCIL** of 26 February 2014 on the harmonisation of the laws of the Member States relating to electromagnetic compatibility (recast)
Text with EEA relevance.

2014/35/UE **DIRECTIVE OF THE EUROPEAN PARLIAMENT AND OF THE COUNCIL** of 26 February 2014 on the harmonisation of the laws of the Member States relating to the making available on the market of electrical equipment designed for use within certain voltage limits

Marek Żupnik spółka komandytowa
32-003 Podłęże, Podłęże 654
NIP 677-002-54-53



mgr inż. Marek Żupnik.